



# F1001 Coriolis Mass Flowmeter

VF1001-001.00-12/04

## Description

Coriolis mass flowmeter is a major advance in mass flow measurement. These meters have got a precedent for accuracy and repeatability under a wide variety of flow conditions. The inherent precision has established it as a standard for numerous industrial applications. The ability of these meters to measure mass flow and density directly has led to their use in applications ranging from metering food products to corrosive chemicals. Coriolis meters have proven extremely reliable when metering noncorrosive fluids. The same reliability can be achieved in corrosive services if consideration is given to the compatibility of the process fluid with the sensor materials of construction. Coriolis technology appealed to us, after all, coriolis is the most accurate technique available for measuring process mass and volume flow.

## Principle

The French mathematician Gustave Coriolis formulated the principle that underlies Coriolis flowmeters. Coriolis showed in 1835 that an inertial force needs to be taken into account when the motion of bodies in a rotating frame of reference is described. Coriolis flowmeters contain one or more vibrating tubes. The fluid to be measured passes through the vibrating tubes. It accelerates as it flows toward the maximum vibration point, and slows down as it leaves that point. This causes the tubes to twist. The amount of twisting is directly proportional to mass flow. Position sensors detect tube positions. The F1001 coriolis mass flowmeter uses two parallel arranged pipes which are rotated at their resonant frequency by coils. Any mass flow passing through the tubes will generate coriolis forces which appear whenever a mass moves radially in a rotating system. The forces have opposed effects on the inlet and outlet sides, they slightly deform the pipes. The excursion of the pipes is detected by sensors on the inlet and outlet side. The phase shift between the rotational frequencies of both pipes are proportional to the mass flow rate. The resonant frequency of both pipes changes in accordance with the density of the medium. This effect determines the density. Using one sensor density and temperature can also be measured. The extent of deformation of the pipes depends on temperature. Therefore the temperature is measured for compensation purposes. Fluid measured can be more extensive, such as the steady uniform flow of common viscosity fluid, the high viscosity fluid, non-Newtonian fluid, slurry containing some solid components and the liquid containing some trace of gas.

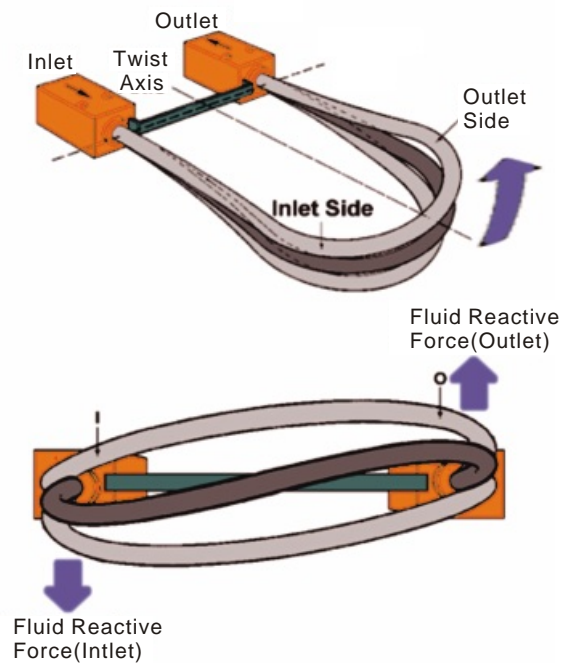
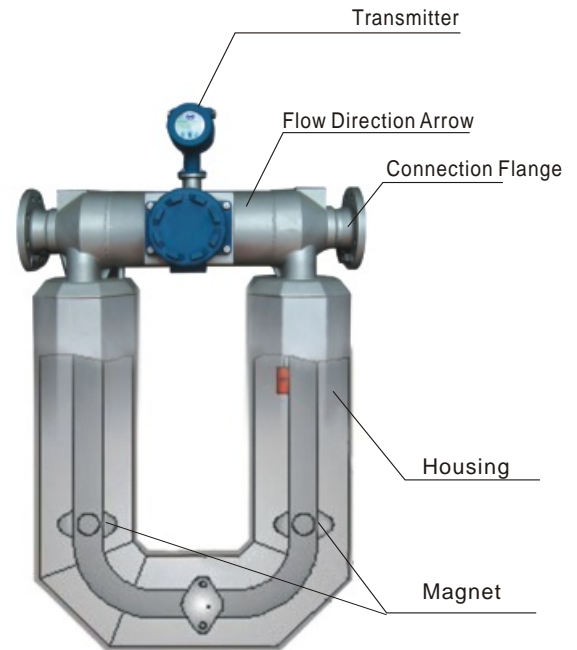

Oscillating Flow Tube, Response To Flow

※ The specifications contained herein are subject to change without notice and any user of said specifications should verify from the manufacturer that the specifications are currently in effect. Otherwise, the manufacturer assumes no responsibility for the use of specifications which may have been changed and are no longer in effect.

# GPE Inc.

**Factory Address:**  
9-17 Libella Court, Essex County, Newark, NJ 07105  
Tel: +1(646)619-1289 Fax: +1(212)400-7201  
[www.gpeus.com](http://www.gpeus.com) [sales@gpeus.com](mailto:sales@gpeus.com)



# F1001

## Coriolis Mass Flowmeter

### Features

- DSP transmitter with superior accuracy  $\pm 0.1\%$
- 20:1 turndown ratio
- 5 to 8 calibration points
- Mass flow, density, temperature and volume flow can be measured at the same time
- Improved startup and availability with simple commissioning and reduced risk
- No moving parts result in no maintenance
- Install anywhere with no flow conditioning or straight pipe required



Micro-bend Version

### Specification

- Flow Range: 16kg/h to 2500t/h
- Connection: Flange/Thread
- Operating Pressure: Customized
- Process Temperature: up to  $+350\text{ }^{\circ}\text{C}$
- Body Material: 304 Stainless Steel
- Measuring Tube Material: 316L Stainless Steel
- Ambient Temperature:  $-40$  to  $+55\text{ }^{\circ}\text{C}$
- Working Humidity: (5% to 95%) RH@ $+25\text{ }^{\circ}\text{C}$
- Accuracy: Up to  $\pm 0.1\%$
- Repeatability:  $\pm 0.05\%$
- Protection: IP 65 (IP 67 optional)
- Approvals: CE, Exd (ib)II CT4
- RS 485 Output
- Pulse Output: 0 to 10 kHz,  $\pm 0.001\% \text{F.S}/^{\circ}\text{C}$
- Current Output: 4 to 20mA,  $\pm 0.005\% \text{F.S}/^{\circ}\text{C}$
- Power Supply: 85 to 265 VAC, 18 to 36 VDC
- Density Measuring:
  - Range: 0.2 to 2.0 kg/l,
  - Repeatability: 0.001 kg/l

### Flow Range (t/h)

Size (mm)	Allowable Flow Range	Normal Flow Range for Accuracy $\pm 0.1\%$	Normal Flow Range for Accuracy $\pm 0.2\%$ & $\pm 0.5\%$	Stability of Zero Point (kg/h)
1/2"	0.04 to 2.00	0.15 to 2.00	0.10 to 2.00	0.2
1"	0.12 to 6.00	0.40 to 6.00	0.30 to 6.00	0.6
1 1/2"	0.60 to 30.0	2.00 to 30.00	1.50 to 30.00	3
2"	1.00 to 50.00	3.50 to 50.00	2.50 to 50.00	5
3"	2.40 to 120.00	60.00 to 120.00	60.00 to 120.00	12
4"	4.00 to 200.00	15.00 to 200.00	10.00 to 200.00	20
6"	10.00 to 500.00	35.00 to 500.00	25.00 to 500.00	50
8"	20.00 to 1000.00	70.00 to 1000.00	50.00 to 1000.00	100
12"	50.00 to 2500.00	170.00 to 2500.00	125.00 to 2500.00	150

\* The specifications contained herein are subject to change without notice and any user of said specifications should verify from the manufacturer that the specifications are currently in effect. Otherwise, the manufacturer assumes no responsibility for the use of specifications which may have been changed and are no longer in effect.

# GPE Inc.

**Factory Address:**  
 9-17 Libella Court, Essex County, Newark, NJ 07105  
 Tel: +1(646)619-1289 Fax: +1(212)400-7201  
[www.gpeus.com](http://www.gpeus.com) [sales@gpeus.com](mailto:sales@gpeus.com)



# F1001

## Coriolis Mass Flowmeter



### Accuracy

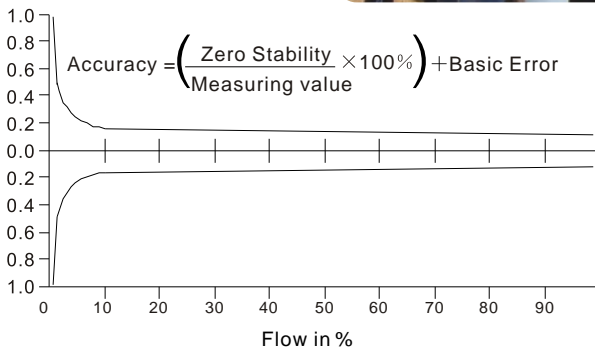

The diagram shows typical values. Individual values may be taken from the calibration records supplied with each meter.

### Repeatability

Accuracy	± 0.10%	± 0.20%	± 0.50%
Repeatability	± 0.05%	± 0.1%	± 0.25%

Accuracy is calculated based on the water measurement under the condition of +20°C to 25°C and 0.1MPa to 0.2MPa.

### Density Measuring

Density Range	( 0.2 to 2.0 ) g/cm <sup>3</sup>
Basic Error	± 0.002g/cm <sup>3</sup> ( Affected by the transducer )
Repeatability	0.001g/cm <sup>3</sup>

※ The specifications contained herein are subject to change without notice and any user of said specifications should verify from the manufacturer that the specifications are currently in effect. Otherwise, the manufacturer assumes no responsibility for the use of specifications which may have been changed and are no longer in effect.

# GPE Inc.

**Factory Address:**  
 9-17 Libella Court, Essex County, Newark, NJ 07105  
 Tel: +1(646)619-1289 Fax: +1(212)400-7201  
[www.gpeus.com](http://www.gpeus.com) [sales@gpeus.com](mailto:sales@gpeus.com)



# F1001

## Coriolis Mass Flowmeter

### Dimension and Weight

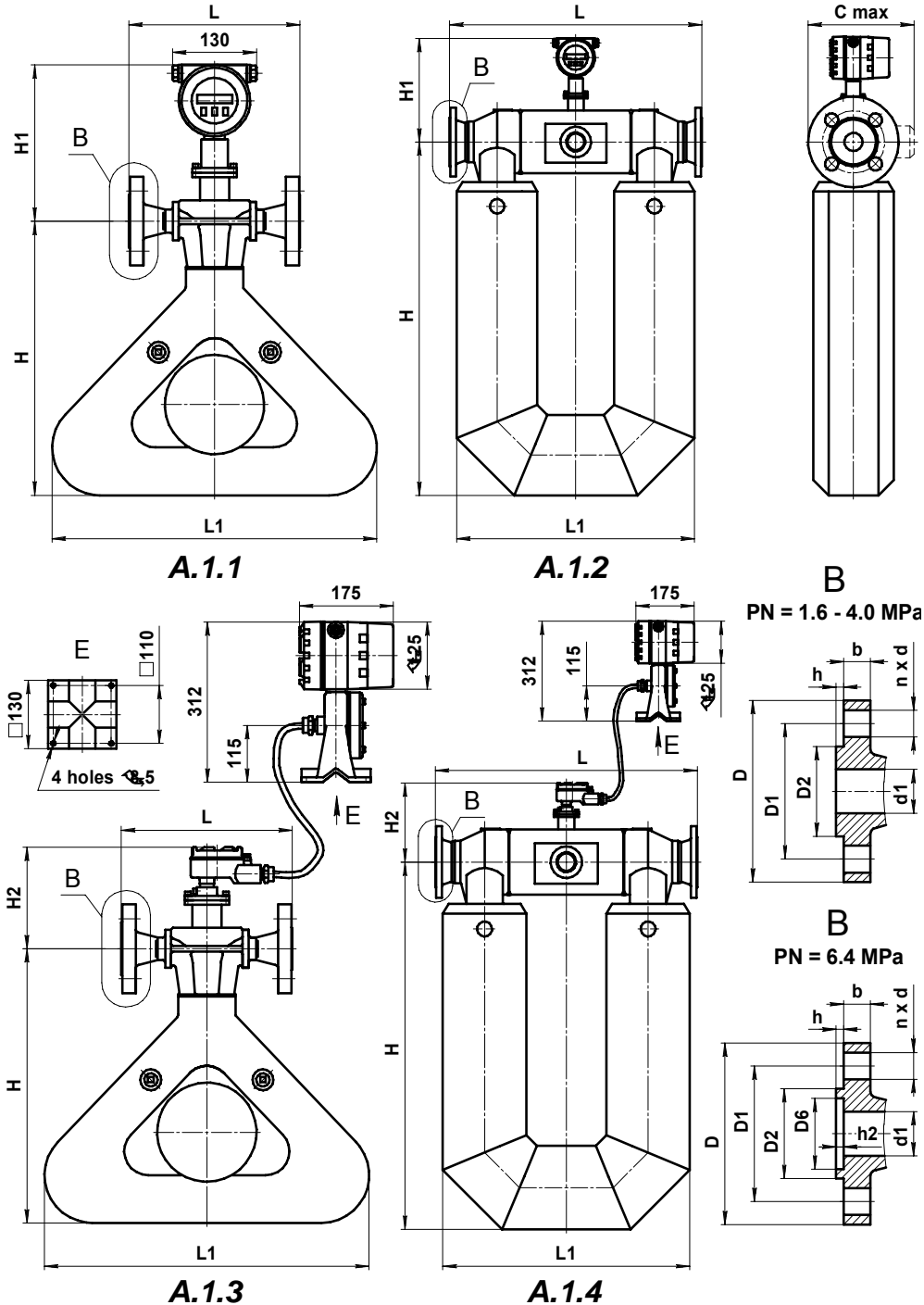

**Figure A.1** Outline dimensions  
 Compact version – Figure A.1.1., A.1.2  
 Remote version – Figure A.1.3, A.1.4

※ The specifications contained herein are subject to change without notice and any user of said specifications should verify from the manufacturer that the specifications are currently in effect. Otherwise, the manufacturer assumes no responsibility for the use of specifications which may have been changed and are no longer in effect.



# F1001

## Coriolis Mass Flowmeter

**Table A.1 – Outline dimensions and weight**

DN, mm	Figure	L, mm		L <sub>1</sub> , mm	H, mm	H <sub>1</sub> , mm	H <sub>2</sub> , mm	C max, mm *	Weight, kg	
		1.6-4.0 MPa	6.4 MPa						A.1.1, A.1.2	A.1.3, A.1.4
010	A.1.1; A.1.3	150	170	350	290	260	130	90	11	14
015	A.1.1; A.1.3	180	192	350	290	260	108	95	11	14
025	A.1.1; A.1.3	200	248	450	400	290	188	115	15	18
040	A.1.2; A.1.4	520	547	470	660	280	182	150	30	33
050	A.1.2; A.1.4	558	588	550	750	290	198	165	35	38
080	A.1.2; A.1.4	780	808	710	1040	320	227	205	80	83
100	A.1.2; A.1.4	920	946	860	1290	350	290	390	185	188
150	A.1.2; A.1.4	1100		1050	1600	380	280	440	320	323
200	A.1.2; A.1.4	1380		1160	1740	420	335	535	625	628

\* Overall width of the body, excluding transmitter

**Table A.2 – Flowmeter flange dimensions**

DN, mm	PN, MPa	d1, mm	D6, mm	D2, mm	D1, mm	D, mm	b, mm	h, mm	h2, mm	n	d, mm
010	1.6; 2.5; 4	10		40	60	90	12	2		4	14
	6.4	8	35	41	70	100	16	4	3	4	14
015	1.6; 2.5; 4	15		46	65	95	12	2		4	14
	6.4	11.6	40	46	75	105	16	4	3	4	14
025	1.6; 2.5; 4	27.3		65	85	115	13	3		4	14
	6.4	24.8	58	65	100	140	20	4	3	4	18
040	1.6; 2.5; 4	41.1		85	110	150	13	3		4	18
	6.4	37	76	84	125	170	22	4	3	4	22
050	1.6; 2.5; 4	52.3		99	125	165	18	2		4	18
	6.4	47	88	99	135	180	22	4	3	4	22
080	1.6; 2.5; 4	79.5		132	160	200	20	2		8	18
	6.4	77	121	132	170	215	24	4	3	8	22
100	1.6; 2.5; 4	101.7		156	190	235	21	3		8	22
	6.4	94	150	156	200	250	25.5	4.5	3.5	8	26
150	1.6; 2.5; 4	154		211	250	300	26	2		8	26
	6.4	142	204	211	280	345	31.5	4.5	3.5	8	33
200	1.6; 2.5; 4	200		285	320	375	35	3		12	30
	6.4	198	260	284	345	415	37.5	4.5	3.5	12	36

※ The specifications contained herein are subject to change without notice and any user of said specifications should verify from the manufacturer that the specifications are currently in effect. Otherwise, the manufacturer assumes no responsibility for the use of specifications which may have been changed and are no longer in effect.



# F1001

## Coriolis Mass Flowmeter

### Model Selection

#### F1001-Series

Example F1001-025AN2COMEX2P1

F1001	Size	Connection	PN	Struct.	Ex	Power	Output	Accuracy	Description
1/2"	015								Size
1"	025								
1 1/2"	040								
2"	050								
3"	080								
4"	100								
6"	150								
8"	200								
12"	300								
ANSI		AN							Flange Standard
DIN		DI							
JIS		JS							
Others		OF							
1.6MPa			1						Max. Working Pressure
2.5MPa			2						
4.0MPa			3						
6.4MPa			4						
Compact Version (-50°C ~ +125°C)				COM					Housing
Remote Version (-50°C ~ +200°C)				REM					
Non-Explosion					NX				Approval
Explosion proof					EX				
DC						1			Power Supply
AC						2			
4 to 20mA/Pulse							P		Signal Output
RS485+Pulse+4 to 20mA							R		
Hart+Pulse+4 to 20mA							H		
±0.1%								1	Accuracy
±0.2%								2	
±0.5%								5	

※ The specifications contained herein are subject to change without notice and any user of said specifications should verify from the manufacturer that the specifications are currently in effect. Otherwise, the manufacturer assumes no responsibility for the use of specifications which may have been changed and are no longer in effect.

# GPE Inc.

**Factory Address:**  
 9-17 Libella Court, Essex County, Newark, NJ 07105  
 Tel: +1(646)619-1289 Fax: +1(212)400-7201  
[www.gpeus.com](http://www.gpeus.com) [sales@gpeus.com](mailto:sales@gpeus.com)